



## CHAIN LOCAL SAMPLE transportation SOP

---

### **Purpose**

The purpose of this SOP is to describe the standard procedures involved in packaging and shipment within the facility to the laboratory.

### **Safety precautions**

This SOP provides guidelines on transportation of all specimens in adherence to strict biosafety measures from sample collection location to the Laboratory processing the samples.

### **Responsibility**

This SOP applies to nursing staff, study clinicians and fieldworkers of study sites who will be undertaking the collection of CHAIN samples. It is the responsibility of the users to follow the guidelines stipulated herein.

The Principal Investigator (through the study coordinator when applicable) retains the overall responsibility of implementation of these standard procedures.

### **Safety/risk assessment**

- Cool boxes and secondary containers used for specimen transport must be inspected for any cracks or damage before use.
- Always use the prescribed Personal Protective Equipment (PPE) while handling specimens before packing for transportation.
- Ensure the primary container is securely closed and leak-proof. Cool boxes and all secondary containers must be tightly closed and should never to be opened until they reach their destination. During vehicle transportation, cool boxes should be placed in a suitable stable location in the vehicle so that they do not move loosely during the journey.
- To protect couriers, drivers and laboratory staff, DO NOT contaminate the secondary container, cool box or the documentation accompanying the specimen. Use gloves only with the primary container as described in the SOP.

### **Definitions & abbreviations**

**Primary container** – This is also called primary receptacle and is a primary watertight, leak-proof receptacle containing the specimen. The receptacle is packaged with enough absorbent material to absorb all fluid in case of breakage or leakage.

**Secondary container** – screw cap container that holds the primary container during transportation. The container should be durable, watertight, leak-proof packaging. It is used to enclose and protect the primary container (receptacle). Several cushioned primary receptacles may be placed in one secondary container, but sufficient additional absorbent material shall be used to absorb all fluid in case of breakage or leakage.

**Specimen** - a sample for medical testing or research.

**Cool Box** – a portable, insulated box (in which ice packs are placed) for use in carrying specimens, keeping them cold.

# CHAIN SAMPLE PACKAGING AND TRANSPORTATION SOP



**IATA** – International Air Transport Association

**WHO** – World Health Organization

## Equipment/materials/reagents

- Cool box
- Secondary container (leak proof container)
- Cold Ice packs
- Zip lock bags
- Specimen Transport inventory form
- Absorbent Tissue
- Thermometer
- Sample Tracking Sheet

## General considerations

Samples are collected and transported to the laboratory for processing and storage on a daily basis. In biomedical laboratories, such exchanges of samples often involve the transport of materials which are considered potentially infectious and are thus classified as “Dangerous Goods”. All materials classified as such must be packaged in ways which will protect all handlers and environments from potentially hazardous exposure to these materials.

## Transport Conditions

Biological specimens or test materials can be very sensitive to the environment to which they are exposed. To obtain reliable results from biological materials, they must be protected from exposure to inappropriate temperature/light/humidity conditions at all times. This is of particular importance for the transport of such materials because it is during transport that samples are most susceptible to exposure to unsuitable conditions.

## Transport Regulations

All transport of biological samples, whether national or international, is highly regulated. All shipments must be packaged & labelled correctly and must be accompanied by prescribed information & documents. Failure to comply with the applicable regulations may render the samples liable to destruction by incineration.

## Sample Shipment methodology

### Specimen/samples transported to the laboratory.

1. Once all the samples to be transported are ready, inform the laboratory (usually by a phone call) of the coming samples so that they get ready to receive and analyse.



- The samples/specimens are packed according to the triple packaging system laid out by WHO/IATA (see illustrations below). However, since these samples only require surface transportation, the packaging materials will be as per the available resources which ensure health and safety of its personnel and the samples. See details in Related Documents: Triple Packaging of Samples.

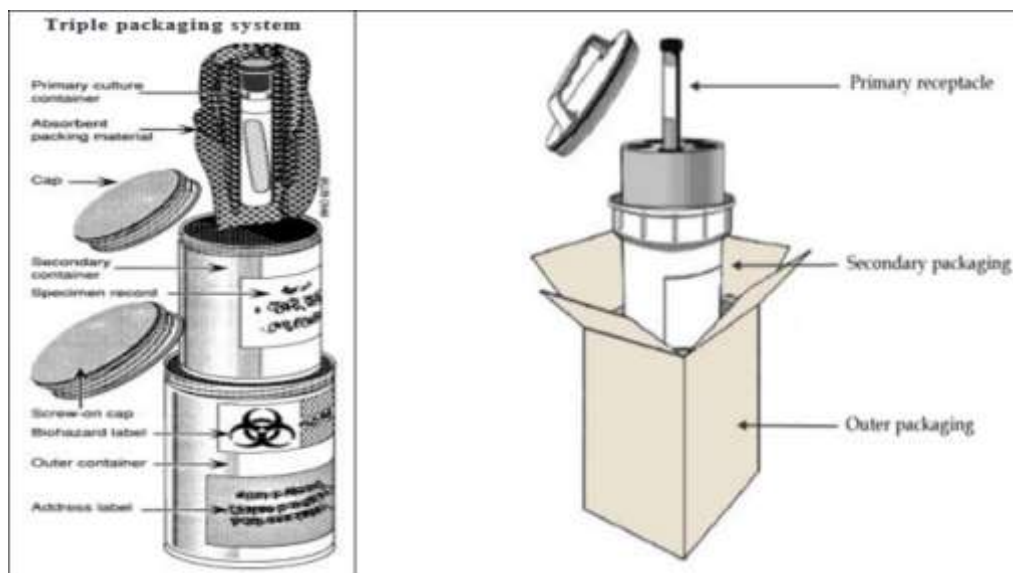

- Check to see that the specimens/samples have been recorded on the sample shipment log.
- Remove gloves used for collecting the sample, wash and disinfect hands properly.
- Take and prepare the cool box.
  - Ensure it is clean and disinfected.
  - Open it and place enough ice packs inside, leaving space for the secondary container.
- Take and open the secondary container, placing the cap close by.
- Wash and disinfect hands; dry them.
- Put on a new pair of gloves.
- Reach for the sample.
- Wrap it in a suitable absorbent material adequately. If you have more than one sample, wrap each one singly/separately.
- Hold the wrapped sample nicely and place it in the secondary container without touching the mouth or sides of the container.
- Remove gloves and wash hands.
- Tightly close the secondary container.



14. Bring the sample request form and place it safely around the secondary container. It is much better if you insert the document into a plastic zip-lock bag for enhanced safety.
15. Put the secondary container into the cool box, close the box tightly in readiness for transport.
16. Ideally, the specimen transport container should be fixed with a thermometer to monitor temperatures, check to ensure the thermometer is calibrated and working before use.
17. Where thermometer is fixed, take the temperature readings at dispatch (start) and at the sample reception (finish). In other cases, confirm the ice pack is cold before dispatch (the consigner, as you pack) and at reception (consignee, when package is opened).
18. Have the specimen/samples received according to specimen reception SOPs at the lab section involved.
19. File the original transport sheet in the laboratory and a copy to remain with the person who transported the specimen/sample.

### **Procedure in case of exposure during an accident**

1. In the event of exposure to any infectious substance, wash or disinfect the affected area as soon as possible, regardless of the agent.
2. Use soap and water to wash or antiseptic solution on the affected skin area, while use 70% alcohol or other appropriate agents to disinfect surfaces affected by the spills.
3. Seek medical advice as soon as possible whenever there is suspected exposure to infectious substances resulting from a damaged package.
4. In the event of a spill, initiate a clean-up procedure used for spills of all infectious substances including blood immediately.
5. The person must be trained on such procedure before performing these steps:
6. Wear gloves and protecting clothing, including face and eye protection if indicated.
7. Cover the spill with a cloth or paper towels to contain it.
8. Pour an appropriate disinfectant over the cloth or paper towels and the immediately surrounding area (5% bleach solutions are generally appropriate).
9. Apply the disinfectant concentrically beginning at the outer margin of the spill area, working towards the centre.

# CHAIN SAMPLE PACKAGING AND TRANSPORTATION SOP



10. Leave contact time of 30 min then clear away the materials. If there is broken glass or other sharps are involved, use a dustpan or a piece of stiff cardboard to collect the materials and place them into a puncture resistant container for disposal.
11. Clean and disinfect the area of the spillage (if necessary, repeat disinfection steps above before this step).
12. Dispose of contaminated materials into a leak-proof, puncture-resistant waste disposal container.

## Triple Packaging of Samples



# CHAIN SAMPLE PACKAGING AND TRANSPORTATION SOP



## Document history

Version	Author	Approved by	Dated
<b>CHAIN LOCAL SAMPLE SHIPMENT SOP</b>	Caroline		

## Site training record

All sites are required to maintain a master copy of this SOP that documents the site staff that have been trained on this SOP.

<b>Document History</b>				
<b>Version No.</b>	<b>Trained staff initials</b>	<b>Signature of trained staff</b>	<b>Date</b>	<b>Trainer's Initials</b>
1.01	KDT	Example row	1 <sup>st</sup> Jan 2016	DM

# CHAIN SAMPLE PACKAGING AND TRANSPORTATION SOP



## Appendices Sample Shipment Log

SITE NAME:		STUDY NAME:				POINT OF ORIGIN:	
DESTINATION:		PI NAME:				DATE:	
Subject ID	Specimen Type*	Sample number	Barcode	Visit No**	Date Collected	Time collected	Comments

SHIPPED BY \_\_\_\_\_ DATE \_\_\_\_\_ (DD/MM/YYYY) TIME \_\_\_\_\_ TEMP: \_\_\_\_\_  
 RECEIVING \_\_\_\_\_ DATE \_\_\_\_\_ (DD/MM/YYYY) TIME \_\_\_\_\_ TEMP: \_\_\_\_\_  
 STORED BY \_\_\_\_\_ DATE \_\_\_\_\_ (DD/MM/YYYY) TIME \_\_\_\_\_

**KEY**  
**Visit Numbers\*\*:**  
**Visit Numbers\*\*:** A0-Admission; D0-Discharge; D21-Day 21; D60 - Day 60, RA – Readmission  
**Specimen Type\*:** Stool (F1, F2, and F3), Blood (Plasma) or Rectal Swab (R1)

